

## FITTING INSTRUCTION

Clamp mark in acc. with		Cables joining
ISO	PN	
1	L	Left directional lights
2	+	Rear fog lights
3	31	Ground
4	R	Right directional lights
5	58R	Right side parking lights
6	54	Stoplights
7	58L	Left side parking lights

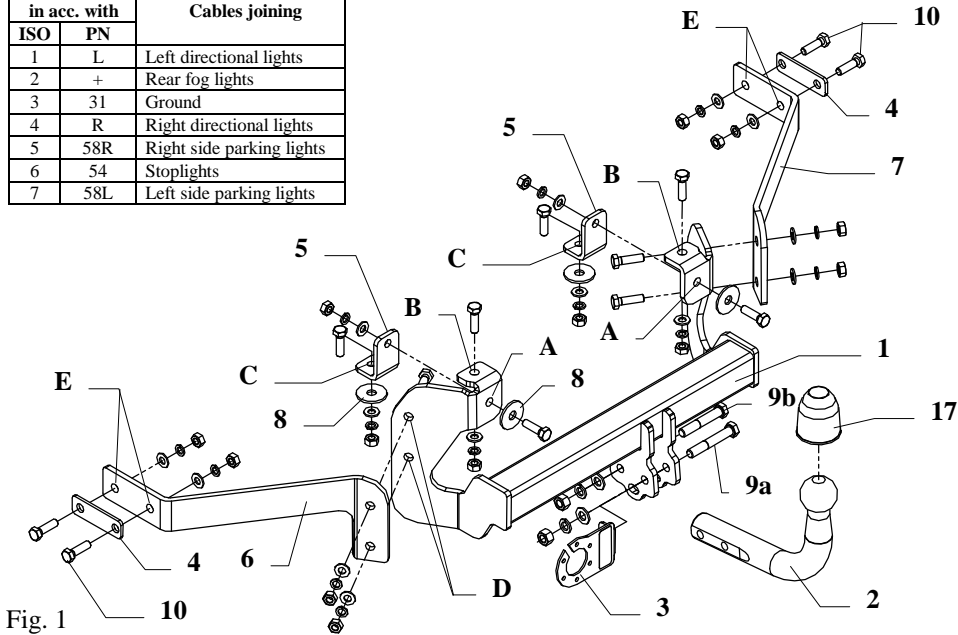

Fig. 1

This towbar is designed to assembly in following cars:

**PEUGEOT 205 3/5 doors**, produced since 1983 till 1998, catalogue number **F02** and is prepared to tow trailers max total weight **1000 kg** and max vertical load **50 kg**.

### *From manufacturer*

Thank you for buying our product. Their reliability has been confirmed in many tests. Reliability of towbar depends also on correct assembly and right operation. For this reasons we kindly ask to read carefully this instruction and apply to hints.

*The towbar should be install in points described by a car producer.*

### Fitting instructions

1. Disassemble the bumper, take the spare wheel out the boot, and lower a muffler.
2. Drill two holes  $\varnothing 12$  mm in the rear panel at the bottom of the car (see fig.2).

3. Position the element (pos. 1) to the chassis and fix it through the just made holes and towbars holes (pos. A) using M10x30mm pos. 10 (use also washers  $\varnothing 42$  mm)
4. Drill  $\varnothing 12$ mm through the towbars holes (pos. B) to the inside part of the boot, then position the elements (pos. 5) in the boot and fix it together using M10x30mm (pos. 10)

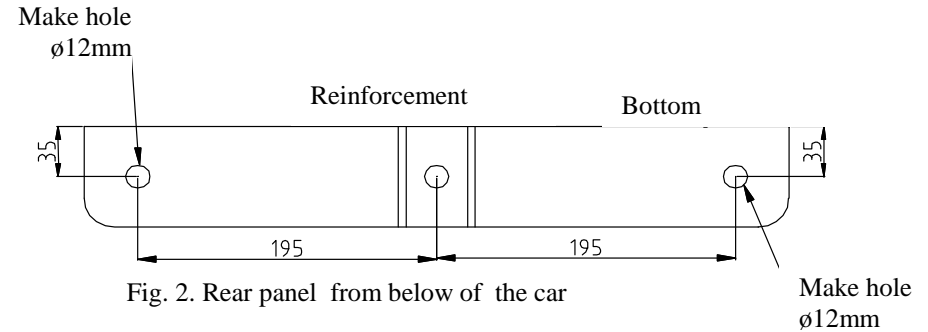

Fig. 2. Rear panel from below of the car

5. Drill  $\varnothing 12$  mm through the holes (pos. C) and fix it using M10x30mm (use the washers  $\varnothing 42$  mm)
6. Position the supports (pos. 6 and 7) to the left and right side of the bar and fix it through the holes (pos. D) using bolts M10x30mm.
7. Drill the holes in the chassis using bit  $\varnothing 12$  mm. Do it through the holes (pos. E). Then fix it through the element (pos. 4) using bolts M10x30mm.
8. Reassemble the bumper and a muffler.
9. Tighten all nuts and bolts according to the torque shown in the table
10. Position the ball of towbar (pos. 2) together with socket plate (pos. 3) and fix it by bolt M12x75mm (pos. 9a) and M12x70mm (pos. 9b) supplied with the towbar.
11. Connect the electric wires according to the instructions of the car
12. Complete the paint cover of towbar (during the mounting paint cover could be destroyed)

### Torque settings for nuts and bolts (8,8):

<b>M8</b>	25 Nm	<b>M10</b>	55 Nm
<b>M12</b>	85 Nm	<b>M14</b>	135 Nm











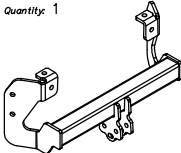

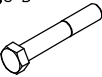

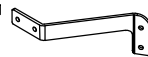

### NOTE

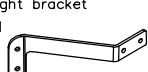
After installation of towbar you should get adequate note in registration book (at authorised service station).The car should be equipped with:

- Indicators
- Tow mirrors

After 1000km check all bolts and nuts. The ball of towbar must be always kept clear and conserve with a grease.

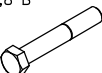
## Towbar accessories:

Pos. 1 Name: Main bar Quantity: 1 	Pos. 5 Name: Angle bar Quantity: 2 	Pos. 9b Name: Bolt 8,8 B Quantity: 1 Dim.: M12x70mm 	Pos. 14 Name: Plain washer Quantity: 14 Dim.: Ø 10,5 mm 
Pos. 2 Name: Tow-ball Quantity: 1 	Pos. 6 Name: Left bracket Quantity: 1 	Pos. 10 Name: Bolt 8,8 B Quantity: 14 Dim.: M10x30mm 	Pos. 15 Name: Spring washer Quantity: 2 Dim.: Ø 12,2 mm 
Pos. 3 Name: Socket plate Quantity: 1 	Pos. 7 Name: Right bracket Quantity: 1 	Pos. 11 Name: Nut 8 B Quantity: 2 Dim.: M12 	Pos. 16 Name: Spring washer Quantity: 14 Dim.: Ø 10,2 mm 
Pos. 4 Name: Fish-plate Quantity: 2 	Pos. 8 Name: Washer Quantity: 4 Dim.: Ø42xØ13x3mm 	Pos. 12 Name: Nut 8 B Quantity: 14 Dim.: M10 	Pos. 17 Name: Ball cover Quantity: 1 
	Pos. 9a Name: Bolt 8,8 B Quantity: 1 Dim.: M12x75mm 	Pos. 13 Name: Plain washer Quantity: 2 Dim.: Ø 13 mm 	



**PPUH AUTO-HAK S.J.**

Produkcja Haków Holowniczych  
Henryk & Zbigniew Nejman  
76-200 SŁUPSK ul. Słoneczna 16K  
tel/fax (059) 8-414-414; 8-414-413  
e-mail: [office@autohak.com.pl](mailto:office@autohak.com.pl)  
[www.autohak.com.pl](http://www.autohak.com.pl)

## Towing hitch (without electrical set)

Class: **A50-X** Cat. no. **F02**

Designed for:

Manufacturer: **PEUGEOT**

Model: **205**

Type: **3/5 doors**

produced since 1983 till 1998

Technical data:

**D-value: 5,19 kN**

maximum trailer weight: **1000 kg**

maximum vertical cup load: **50 kg**

**Approval number acc. to regulations EKG/ONZ 55.01: E20-55R-01 0939**

## Foreword

This towing hitch is designed according to rules of safety traffic regulations. The towing hitch is a safety component and can be install only by qualified personnel. Any alteration or conversion of the towing hitch is prohibited and would lead to cancellation of design certification. Remove insulating compound and underseal from vehicle (if present) in the area of the matting surfaces of the towing hitch. The vehicle manufacturer's specifications regarding trailer load and max. vertical cup mass are decisive for driving whereat values for the towing hitch cannot be exceeded.

*D-value formula:*

$$\frac{\text{Max trailer weight [kg]} \times \text{Max vehicle weight [kg]}}{\text{Max trailer weight [kg]} + \text{Max vehicle weight [kg]}} \times \frac{9,81}{1000} = D \text{ [kN]}$$